

Lock Guard



Features

- Made in the USA with USA Steel
- Meticulously welded and finished for long life and function
- Easy weldable assembly for easy installation into new or existing pedestrian gate
- 24" high, 12" half-moon wide and 4" deep for complete surround of lock lever and unencumbered lever access



TORXUN Lock Guard

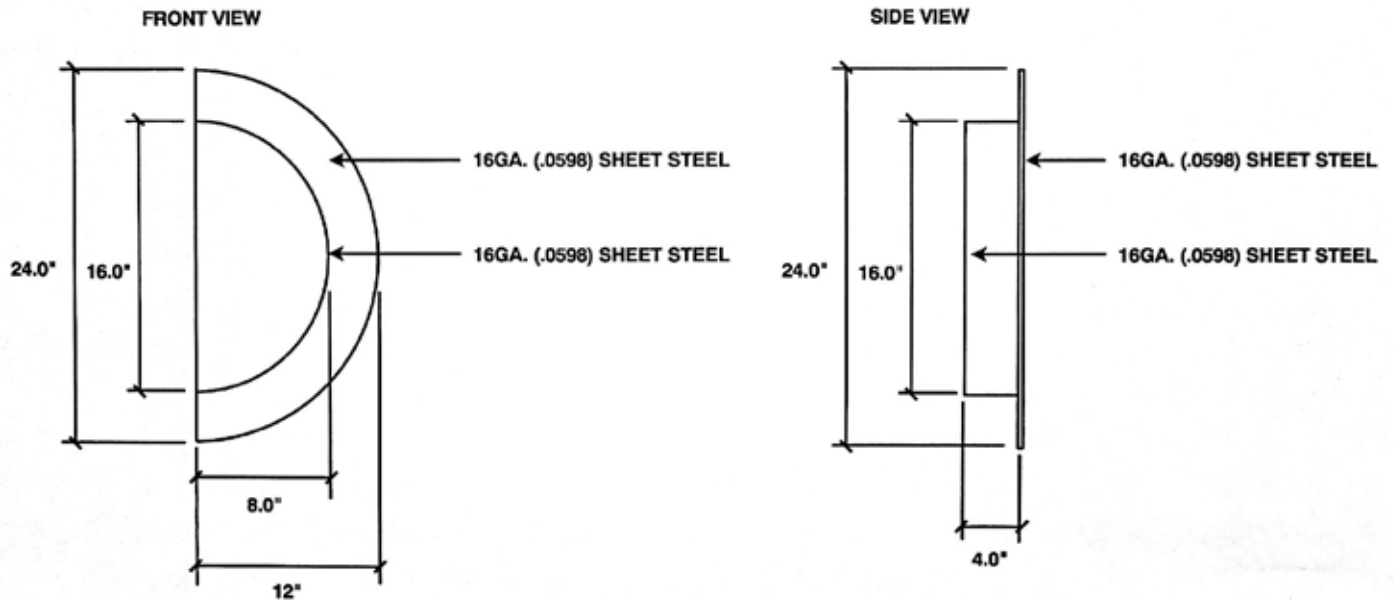

Technical Data

Facility	Data	
Sheet metal	16 GA	
Handle Guard	Height	16"
	Width	8"
	Depth	4"
Flat plate dimensions	24" x 12"	

Product	Part #
Black powder coating	9912.001P
No coating	9912.001R

Other finishes available.
Please call.

About TORXUN

TORXUN Vehicle Access Technologies engineers architectural-grade products for vehicle access controlled systems. Everything is produced in Tracy, California.



Precision Handcrafted
in Northern California
from U.S. Steel.